

gamma

Gamma Equipos S.A. de C.V.



 **Carver[®]**

Creating Value.

About Us

Since we built our first pumps in 1938, the Carver name has become synonymous with value. Today we are recognized as one of the world's leading centrifugal pump companies, building pumps to the most demanding engineering specifications and military standards in the world.

Our company is located in Muscatine, Iowa, 25 miles southwest of the Quad Cities area. Our operations there include modern manufacturing equipment and pump development software, and we are committed to the highest quality possible – in our products and our people. Along these lines, Carver was also one of the first American pump companies to attain ISO 9001 certification – the most recognized standard for quality in the world.



This certification is also your assurance that our commitment to quality isn't limited to our hardware, but to superior customer service, leading edge R & D, and continuous improvement in everything we do as well. In short, at Carver we do it right the first time, every time.



From an applications standpoint Carver has traditionally focused on the Industrial and Marine markets. Within these markets we build pumps for handling water, oil, and chemicals for both the public and private sectors.

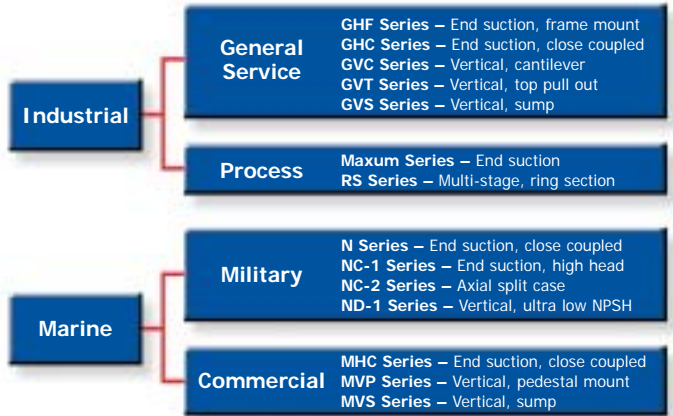

These markets, however, are by no means the only ones we are active in. In fact, it is hard to find an industry, market, or service today that doesn't use a Carver pump as its prime fluid mover.

Either way, our pumps all carry the same Carver trademark: lasting value from solid, straightforward designs that provide many years of service. So whether the job is refueling fighter jets on the deck of an aircraft carrier, supplying paint to an auto assembly line, or bringing water to the fountain in a city park, we put our reputation on the line every day with every pump we build.

Our product line includes both horizontal and vertical end suction, multi-stage, axial split case, self-priming, and solids-handling pumps.

Running at standard motor speeds of 3500 RPM, 1750 RPM, and/or 1150 RPM, together they cover a hydraulic range to 10,000 GPM and 2,800 ft. TDH.

HYDRAULIC COVERAGE

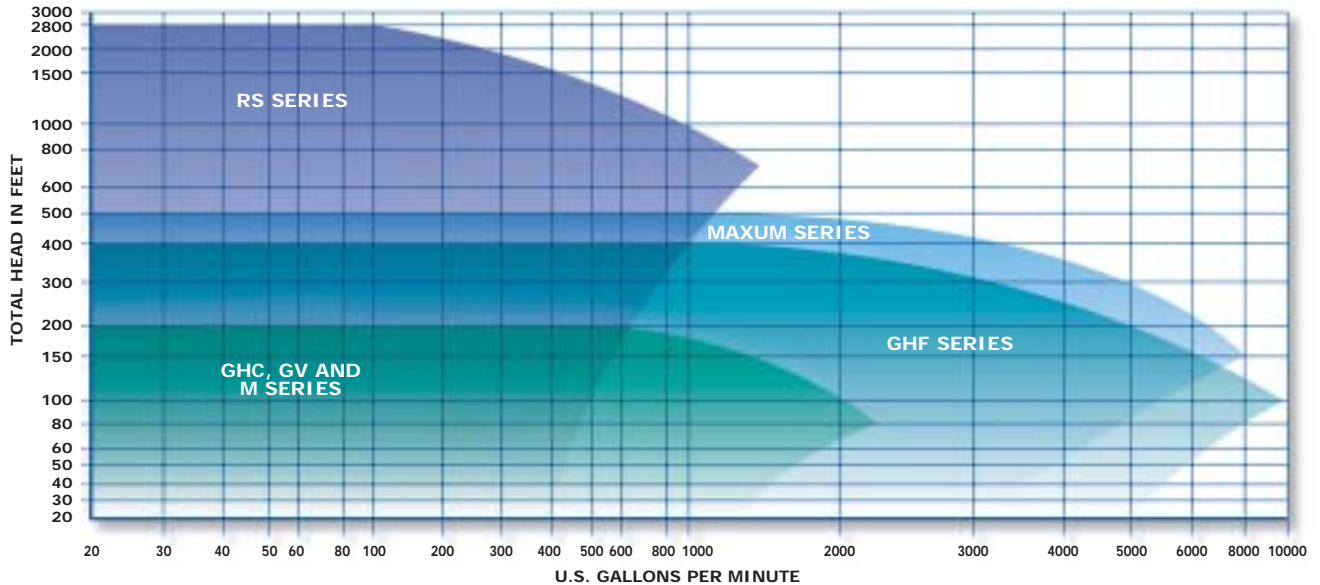

Our pumps are also backed by unparalleled aftermarket support. Our network of 70 stocking distributors, manufacturer's representatives, and certified service centers throughout the world means that no matter where your pump may be installed, there are local sales and service people ready to support your aftermarket needs.

And, through our website, you can select pumps, locate your local Carver agent, download a sales brochure or Operating and Maintenance Manual, order replacement parts, or even send us your inquiry for a new pump.



Approval Certification Number 95-370

Industrial Pumps for General Service and Process Appl

For General Service applications we offer horizontal and vertical pumps. Our GHF and GHC Series horizontal pumps are available in close coupled or frame mounted arrangements. These pumps are offered in cast iron, bronze or 316 SS fitted cast iron, or all 316 SS executions.



Standard features include a back pull-out design for simplified maintenance and inspection ease and 316 SS shaft sleeves for extended life expectancy. The close coupled pumps have the added option of either JM or JP shaft extension motors.

Our GVC and GVT Series vertical pumps are available as standard tank mounted units or the more operator-friendly top pull out designs for depths to 36 inches. For anything deeper the GVS Series sump pump is offered for depths to 20 feet. All are available in cast iron, 316 SS fitted cast iron, or all 316 SS executions and come with a broad selection of discharge piping, top plate, and underliner choices.

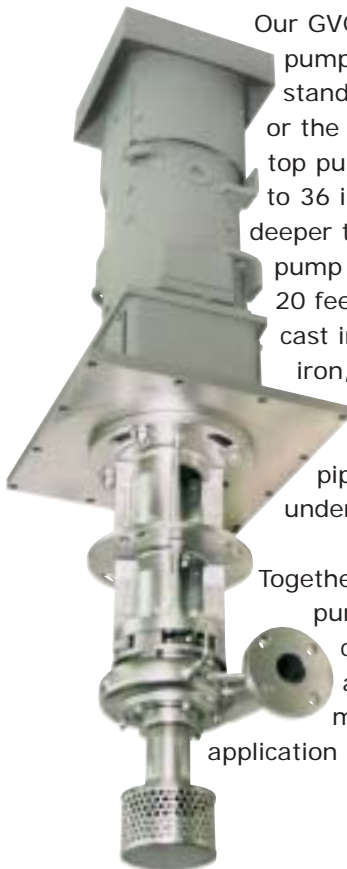

Together these General Service pumps offer hydraulic coverage to 10,000 GPM and 500 ft. TDH, which makes it hard to find an application we can't handle.

In addition to these standard pumps, we also bring the benefit of 60 years experience in special application pumps. So, if you require special flows, pressures, temperatures, mounting, or drive configurations, we can create a pump specifically for you.

Automotive & General Manufacturing

- Coatings and spray paint systems
- Circulating water supply
- Machine coolant recovery
- Parts washers circulation
- Sump collection and drain
- Wastewater treatment systems

OEM Systems

- Boiler tube cleaning
- Commercial dishwashers
- Fluid filtering
- Large vehicle washers
- Reverse osmosis / desalinization
- Sanitary wash down
- Turbomachinery lube oil supply
- Ultra high purity water wash systems
- Various other proprietary systems

Agricultural, Commercial, Municipal and Recreational

- Amusement park water slides
- Cooling tower water circulation
- District water supply
- Farm irrigation
- Fire fighting systems
- Ski resort snow making
- High-rise building sprinkler systems
- Pressure boosting

In the Process Industries, Carver can be found wherever heavy-duty pumps are specified. Our process pumps include a full range of horizontal, vertical, multi-stage ring section, self-priming, and solids handling designs.



The Maxum Series is an end suction pump designed for the needs of the ANSI and API pump markets.

Available as either

foot or centerline mounted, they provide flows to 10,000 GPM and heads to 450 ft. with steel, 316 SS, CD4MCu, Alloy 20, Hastelloy B or C, Monel, and titanium material options.

The RS Series ring section, multi-stage pumps are available as horizontal or vertical units. The RS6 has 600 lb. flanges for heads to 1,900 ft. while the RS9 has 900 lb. flanges for discharge heads to 2,800 ft.

Both are available in ductile iron or CD4MCu with iron, bronze, or CD4MCu internals. And, like the Maxum Series, the RS can be motor or turbine driven and is available in high temperature and magnetic drive arrangements

as well.



Our pumps are engineered to handle high flows, high pressures, extreme temperatures, aggressive materials, and/or entrained solids that are typical in:

Chemical Processing

- Acids and solvents transfer
- Caustic solution transfer
- Ethane and polyethane
- Phosphoric and sulfuric acids

Mining

- Acid leaching processes
- Ground water evacuation
- Underground mine dewatering
- Wastewater treatment

Refining

- Hot oil applications
- Light hydrocarbon transfer
- Liquid sulfur transfer
- Monomer, polymer and resins
- Off site loading and transfer

Power Generation

- Boiler feed pumps
- Condensate return
- Deaerator circulation
- Deionized water transfer
- NOx water transfer
- Oil lubrication for rotating equipment

Pulp and Paper

- Black, green and white liquor
- Boiler feed systems
- Caustic and chemical feed
- Raw water supply
- Trash, effluent and wastewater

Accessories and auxiliaries such as seal flush systems, vibration detectors, vapor tight vertical configurations, and full API baseplates are all common for us. Complete performance testing is also available as required.



Marine Pumps for Military and Commercial Application

For Marine applications our pumps can be found on just about anything that floats. Not only are we a mainstay in the Commercial Marine industry, we also are proud of our long-term partnerships with the Military Sealift Command and U.S. Coast Guard and have been a supplier on every major Navy shipbuilding program of the last 40 years.



Our shipboard pumps include a wide assortment of end suction (close coupled or frame mounted), horizontally or vertically mounted, axially split-case, low NPSH vertical in-line pumps.

All of these pumps meet the strenuous military specifications for high impact shock loading, environmental impact, vibration, and structure-borne, fluid-borne and air-borne noise.

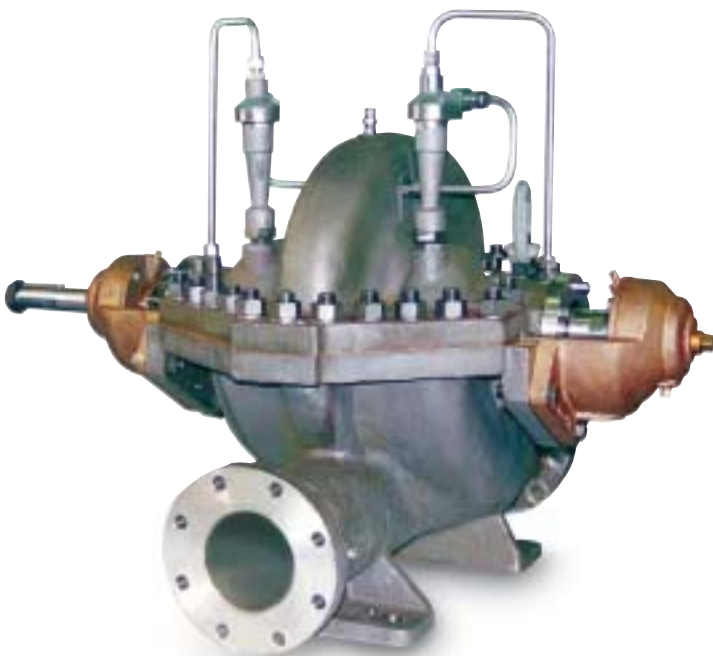

As an example of our role in the U.S. defense effort, our pumps are a part of such recent U.S. Navy defense programs as:

- Arleigh Burke Class Destroyers
- Nimitz Class Nuclear Aircraft Carriers
- Osprey Class Minehunters
- San Antonio Class Amphibious Assault Ships
- Strategic Sealift RO/RO Cargo Ships
- T-ADC(X) Dry Cargo Transfer ships
- Tarawa Class Amphibious Assault Ships
- Ticonderoga Class Guided Missile Cruisers
- Virginia Class Attack Submarines
- Wasp Class Amphibious Assault Ships
- Whidbey Island Class Landing Ships

Onboard these vessels our pumps are used for virtually every pumping application, including:

- Air conditioning chilled water
- Anti fire fighting foam (AFFF)
- Bilge transfer
- Distilling plant feed, distillate, and brine overboard
- Electronics systems cooling
- Main and auxiliary engine cooling
- Main and auxiliary seawater ballast
- Main boiler feed and condensate
- Main fire fighting
- JP-5 fuel supply to jet fighters
- Potable water supply
- Radar system cooling
- Waste water recycling

We are also a partner with the U.S. defense industry on many leading edge R & D initiatives, working with them to develop and improve the pumps of tomorrow.

gamma

Gamma Equipos S.A. de C.V.

On the Commercial Marine side we have a full line of both horizontal and vertical pumps. The

MHF is our horizontal close coupled series. Our vertical pumps include the MVP vertical in-line, pedestal mounted series, and the MVS vertical sump series capable of pumping from tanks 20 feet below deck.



These pumps are available in ductile iron (all iron, bronze or 316 SS fitted), 316 SS, Ni-Al-Brz, and titanium executions. We have also developed a new, proprietary high strength, corrosion resistant

composite material for our pump internals.

This advanced material, which has already been put into service by the U.S. Navy, is just another example of how Carver creates value for our customers.



Designed for onboard pumping of fresh water, seawater, and other fluids, these pumps can be used on everything from U.S. Coast Guard cutters and icebreakers to barges, ocean-going tankers, workboats, ferry boats, small pleasure craft, and even luxury yachts.



In addition, Carver is the only U.S. pump manufacturer to have been chosen to supply pumps for the Project America Cruise Ships – the first large cruise ships to be built in the U.S. in over four decades.

Engineered for reliability with a minimum of space required, our Commercial Marine pumps are all built in accordance with ASTM F-998, USCG and American Bureau of Shipping (ABS) requirements and can be tested to government shock and vibration specifications. Certifications from the various technical societies (Lloyd's, Det Norske Veritas, etc.) can also be obtained.

Most importantly, as with all our other pumps, these pumps offer the reliability, low total life cost, and lasting value that has made Carver one of the most trusted names in pumps.



 **Carver**

Carver Pump Company

2415 Park Avenue • Muscatine, IA 52761
563.263.3410 • Fax: 563.262.0510

www.carverpump.com

gamma

Gamma Equipos S.A. de C.V.